

Hochtemperatur-Ringdrosselklappe

High temperature butterfly valve

HT-L

- **Robuste Industrierausführung**
 - **Zum Einklemmen zwischen Flanschen PN 6/10/16 und ANSI**
 - **Temperaturverlängerung optional**
 - **Hochdruck-Stopfbuchspackung mit Grafitdichtung**
 - **Verlängerter Hals für Isolierung auf Anfrage**
 - **2. Wellenende optional (z.B. für Initiatorabfrage)**
-
- *Sturdy industrial design*
 - *To be mounted between flanges PN 6/10/16 and ANSI*
 - *Temperature extension optional*
 - *High pressure packing box with graphite sealing*
 - *Extended neck for insulation on request*
 - *2nd shaft end optional (for proximity switch etc.)*

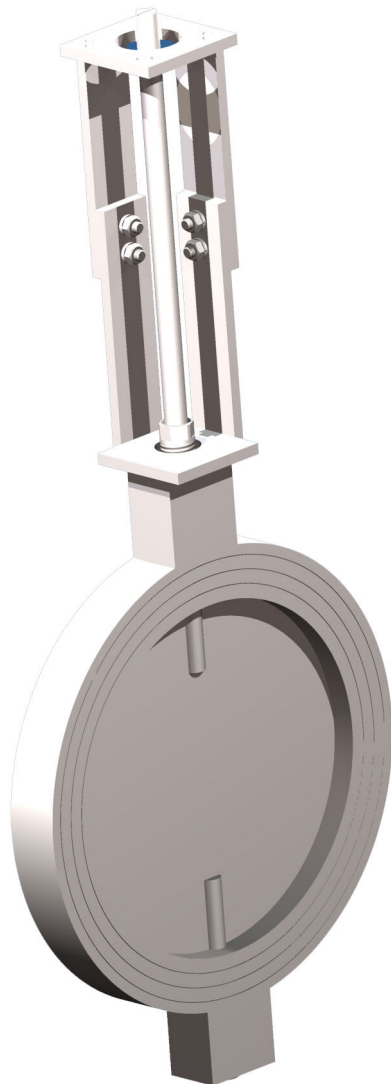

Durchschlagend <i>Swing-through</i>	•
Anschlagleiste <i>Stop bar</i>	•
Anschlagleiste und Dichteinlage <i>Stop bar with packing insert</i>	•
Dichtschließend <i>Shut-off</i>	—
Manuell <i>Manual operated</i>	•
Elektrisch <i>Electrical</i>	IL/CL
Pneumatisch <i>Pneumatical</i>	PD/PE
Max. Betriebstemperatur <i>Max. operating temperature</i>	750 °C

Material <i>Material</i>	Temp. bis / Temp. up to		
	400 °C	600 °C	750 °C
Gehäuse <i>Housing</i>	1.0570	1.4301	1.4878
Scheibe <i>Valve plate</i>	1.0038	1.4301	1.4878
Welle <i>Shaft</i>	1.0050	1.4301	1.4878



Hochtemperatur-Ringdrosselklappe

High temperature butterfly valve

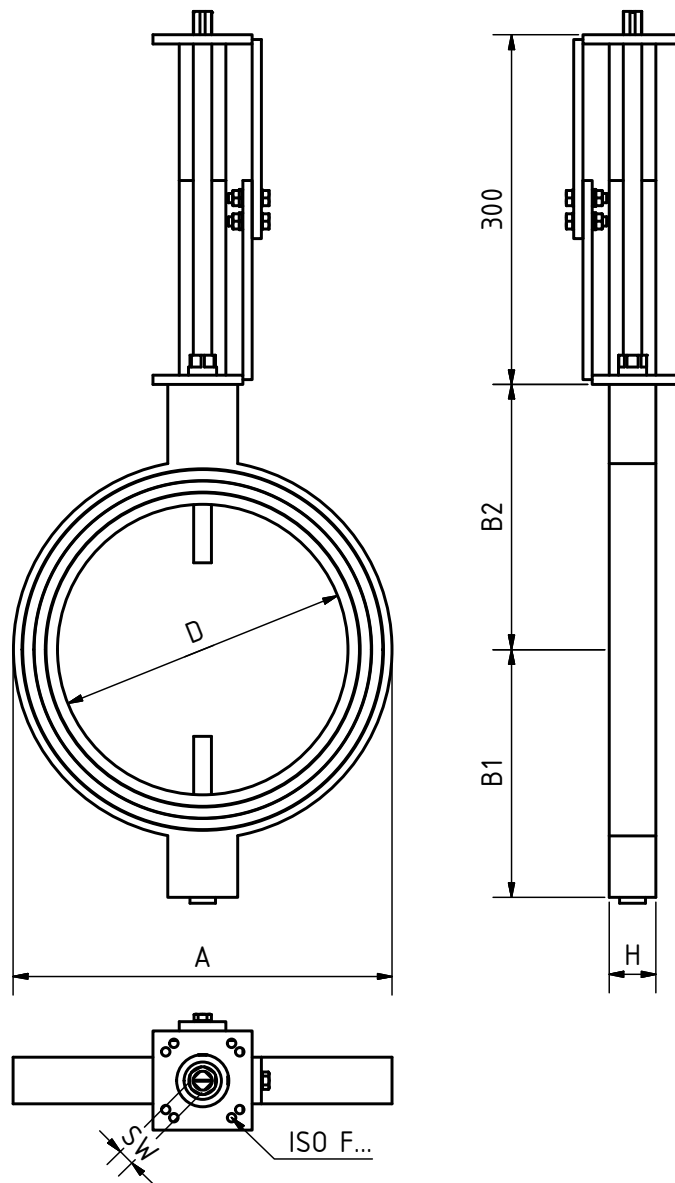

DN	D	A	B1	B2	H	SW	ISO F...
50	49	105	80	100	30	14	05
65	64	125	90	110			
80	79	140	100	120			
100	99	160	110	130			
125	124	190	120	140			
150	149	215	140	160	40	17	07
200	199	270	170	190			
250	249	325	200	220			
300	295	375	230	250	50	17	07
350	340	430	250	270			
400	390	485	280	300			
500	490	590	345	360			

Maße in mm / Änderungen vorbehalten
Dimensions in mm / Subject to change

