

LINEARIS

Electrical linear motion drive / Damper actuator

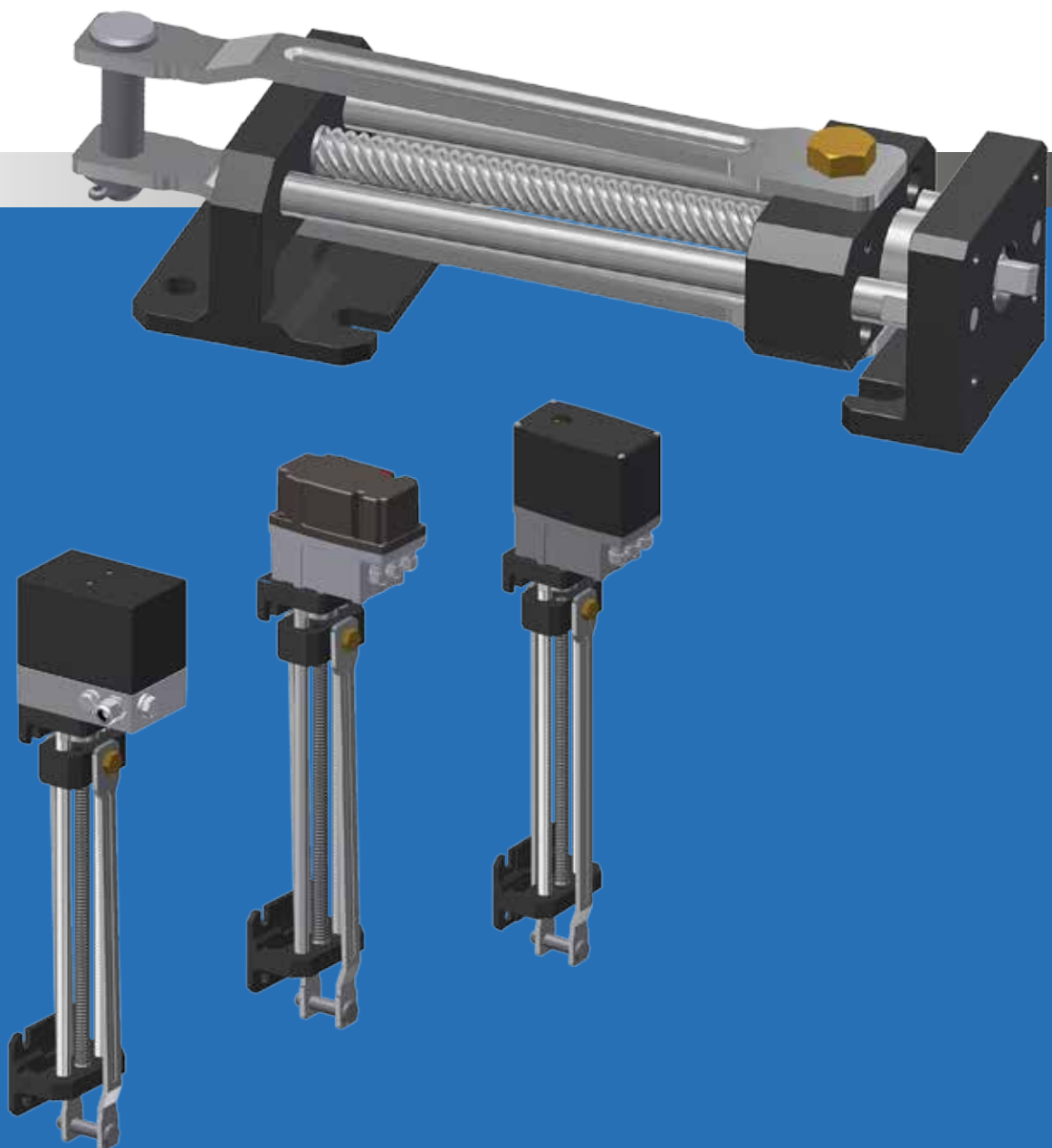

LINEARIS

Drive head Tensor

- Universal, sturdy industrial design
- Lifetime lubrication, maintenance-free
- Mountable in arbitrary positions
- Short-circuit proof synchronous motor
- Finely adjustable actuating cams
- Numerous options such as additional switch, potentiometer, position indicator, controller, hand wheel etc.
- Control card PMR optional



Specifications

Actuating force	max. 1800 N (higher forces upon request)
Actuating time	0.7 mm...3.3 mm/s (load independent at AC)
Travel	150/300 mm stroke (other strokes upon request)
Voltage	Multi current power supply unit 85...265 V AC (alternative AC/DC low voltage power supply)
Ambient temperature	-15 °C...+60 °C
Protection class	IP 65
Duty cycle	100%

LABS-free according to Daimler testing standard certified by Fraunhofer Institute.

Drive unit

Type Linearis TE	Force N	Actuating time mm/s
06-07	600	0.7
06-17	600	1.7
06-20	600	2.0
06-33	600	3.3
12-07	1200	0.7
12-17	1200	1.7
12-25	1200	2.5
18-07	1800	0.7
18-10	1800	1.0
18-13	1800	1.3

Type Linearis TE-DC	Force N	Actuating time mm/s
06-07	600	0.7
06-17	600	1.7
06-20	600	2.0
06-33	600	3.3
12-07	1200	0.7
12-17	1200	1.7
12-25	1200	2.5
18-07	1800	0.7
18-10	1800	1.0
18-13	1800	1.3

Intermediate values upon request

Linear unit

Type	Stroke mm	Weight (incl. actuator) kg
150	150	8
300	300	9

More stroke lengths upon request.

Type example: Linearis 06-33 150 —> Damper actuator 600 N (3.3 mm/s) with 150 mm lift unit.

Drive head Nano+

- Sturdy industrial design
- Independant installation position
- Maintenance-free
- Short-circuit proof synchronous motor
- Finely adjustable actuating cams
- Numerous options as additional switches, potentiometer, position indicator, manual override etc.
- Controller PMR-Nano optional



Specifications

Actuating force	max. 1800 N (higher forces upon request)
Actuating time	0.7 mm...3.3 mm/s (load independant at AC)
Travel	150/300 mm Hub (more stroke lengths upon request)
Voltage	230V AC. 50/60 Hz (Option 24/115V AC. 24V DC)
Ambient temperature	-15 °C...+60 °C
Protection class	IP 65
Duty cycle	100%

LABS-free according to Daimler testing standard certified by Fraunhofer Institute.

Drive unit

Type Linearis N+	Force N	Actuating time mm/s	Voltage
06-07	600	0.7	230 V AC 115 V AC 24 V AC
06-17	600	1.7	
06-33	600	3.3	
12-07	1200	0.7	
12-17	1200	1.7	
12-33	1200	3.3	
18-07	1800	0.7	
18-17	1800	1.7	
06-10	600	1.0	
06-20	600	2.0	
06-50	600	5.0	
12-10	1200	1.0	
12-17	1200	1.7	
12-23	1200	2.3	
18-07	1800	0.7	
18-10	1800	1.0	
18-20	1800	2.0	

Intermediate values upon request

Linear unit

Type	Stroke mm	Weight (incl. actuator) kg
150	150	8.5
300	300	9.0

More stroke lengths upon request.

Type example: Linearis N+ 06-33 150 —> Damper actuator 600 N (3.3 mm/s) with 150 mm lift unit.

LINEARIS

Drive head CL

- Universal, sturdy industrial design
- Lifetime lubrication, maintenance-free
- Mountable in arbitrary positions
- Short-circuit proof synchronous motor
- Finely adjustable actuating cams
- Numerous options such as additional switch, potentiometer, position indicator, controller, hand wheel etc.
- Cover height H98-H178, depending on options
- Control card PMR-CL optional



Specifications

Actuating force	max. 3200 N
Actuating time	1.3 mm...6.7 mm/s (load independent at AC)
Travel	150/300 mm stroke (other strokes upon request)
Voltage	230V AC, 50/60 Hz (Option 24/115V AC, 400V DS, 12/24V DC)
Ambient temperature	-15 °C...+60 °C (Option -40 °C...+80 °C)
Protection class	IP 65
Duty cycle	100%

LABS-free according to Daimler testing standard certified by Fraunhofer Institute.



Drive unit

Type Linearis CL	Force N	Actuating time mm/s	Voltage	
06-17	600	1.7	230 V AC 115 V AC 24 V AC	
06-20	600	2		
06-33	600	3.3		
06-67	600	6.7		
12-17	1200	1.7		
12-25	1200	2.5		
12-33	1200	3.3		
12-71	1200	7.1		
18-14	1800	1.4		
18-37	1800	3.7		
25-14	2500	1.4		
25-37	2500	3.7		
32-14	3200	1.4		
32-37	3200	3.7		
Type Linearis CL-DC	Force N	Actuating time mm/s		Voltage
06-17	600	1.7		24 V DC
06-33	600	3.3		
06-51	600	5.1		
06-85	600	8.5		
12-17	1200	1.7		
12-33	1200	3.3		
12-51	1200	5.1		
12-85	1200	8.5		
18-17	1800	1.7		
18-56	1800	5.6		
25-17	2500	1.7		
25-56	2500	3.3		
32-17	3200	1.7		
32-56	3200	3.3		

Lift unit

Type	Stroke mm	Weight (incl. actuator) kg
150	150	9
300	300	10

More stroke lengths upon request.

Type example: Linearis 06-33 150 → Damper actuator 600 N (3.3 mm/s) with 150 mm lift unit.

LINEARIS

Linear unit

- Stainless steel high-helix lead screw Ø18
- Lead 40 mm with optimized efficiency
 - less turns per stroke length
 - long-life motor
 - slow and smooth motor movement
 - low noise and vibration
- Holding torque by self-hold of the actuator
- Separately exchangeable actuator
- High-strength, anodized aluminum milled parts, corrosion resistant and lightweight
- Long holes for fastening, i.e. easy installation
- Maintenance-free by dry-run, no lubrication necessary.
No dirt deposits on grease (longer life span)
- Embedded (dry) lubricants inside the lead screw nut
- Easily exchangeable with ARIS damper actuators delivered till 2014
- High quality „dryspin® technology“. Lead screw and nut made by igus©

Materials linear unit

Bearing support	EN AW 7075
Holder lead screw nut	EN AW 7075
Connecting rod	Steel, galvanized
High-helix lead screw	1.4301
Twist lock	1.4301
Thrust collar	1.4021
Lead screw nut	Up to 2500 N: iglidur® J 2500...3200 N: Brass nut (CuSn12) with grease nipple
Connecting rod pin	Brass
Stroke limiter	1.4301
Bushings	igidur® J
Bolts	Steel, galvanized



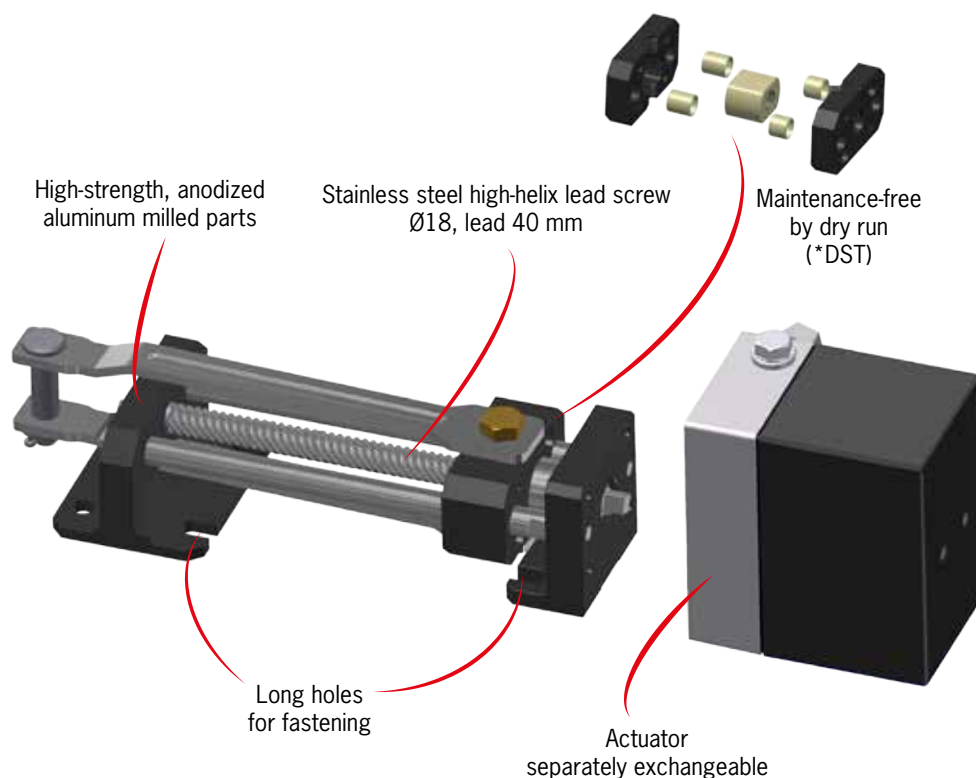

*** dryspin® technology high-helix: Higher life span and efficiency**

The dryspin® technology is based on wear-resistant igus® high performance polymers, specially designed for screw drives, dryspin® offers a higher life span and efficiency to high-helices by their characteristics and geometries, specially matched to the nut and lead screw. By their freedom from lubrication, dryspin® screw drives are suitable for usage in rough industrial just as in clean and hygienic environments (e.g. laboratory automation).

dryspin® lead screw (up to 2500 N)

- Lubricant-free
- High-tech polymer iglidur® J inside aluminum block
- Optimal transmission of the torque by form closure
- Vibration-isolating
- Smooth and steady run

Drives dimensions

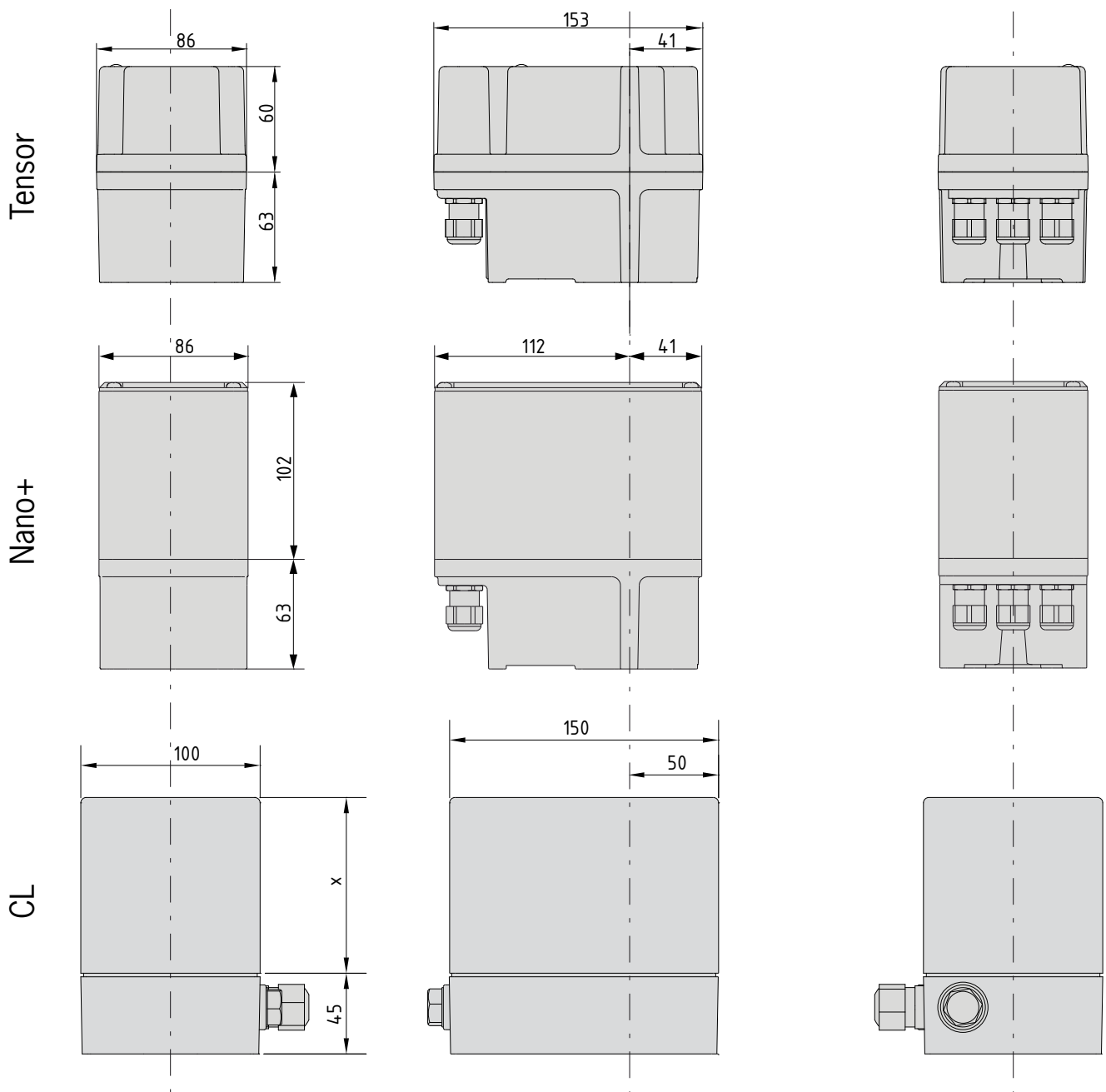

X (cover height) depending on options: 98–178 mm

LINEARIS

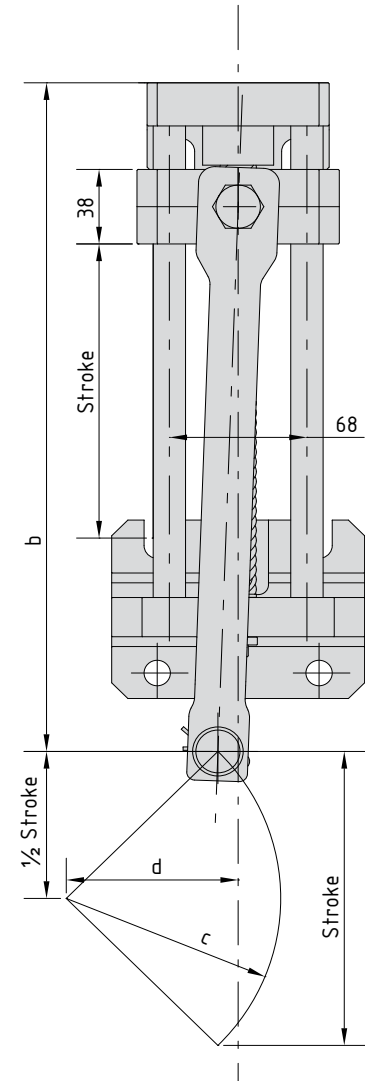
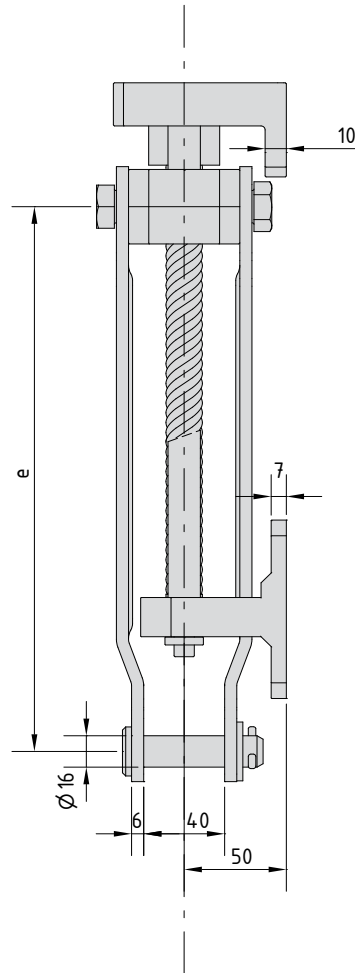
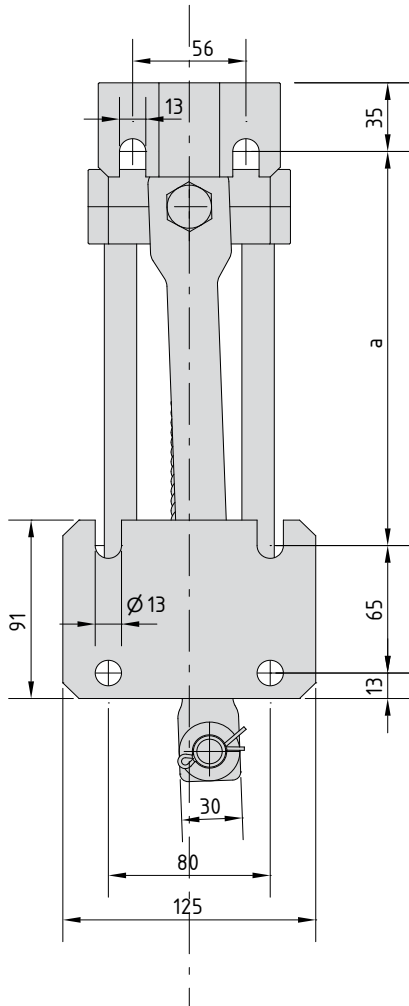

Stroke	a	b	c	d	e
150	201	341	106	85	278
300	351	491	212	170	428

LINEARIS Ex

Damper actuator for explosive atmospheres

Ex II 2G Ex d IIC T6 Gb

- Usable in Ex-Zones 1 and 2
- Appliance categories 2G and 3G
- Flameproof „d“
- Usable at gases with increased flame transmission capacity „C“
- Highest temperature class T6
- For gases with ignition temperature > 85 °C

Ambient temperature	-20 °C...+60 °C
Cable entry	1x M20 x 1.5 bzw. 1x M20 x 1.5 + 1x M16x1.5
Housing	Aluminum (painted), Ground plate: steel
Ex protection	Ex II 2G Ex d IIC T6 Gb
Protection class	IP65



Subject to technical changes.

ARIS bridges gaps

You are faced with a problem in your system and are looking for an alternative or new solution?

40 years of experience and expertise in-house. Through newly created capacities our design department is located back at ARIS headquarters in Troisdorf/Germany in 2014. We develop and build high-quality electric actuators that are equipped with contemporary technology. Drives made by ARIS are created in close cooperation of engineers, technicians and the sales team with our clients. So we are able to develop marketable products from scratch and execute to the production stage under one roof. In addition to standard products, we can implement individual solutions for customer projects as well as special drives as OEM goods.



Come to ARIS – Your specialist for modern actuator technology „Made in Germany“.



ARIS Stellantriebe GmbH • Rotter Viehtrift 9 • D-53842 Troisdorf
Telefon +49 2241 25186-0 • aris@stellantriebe.de